

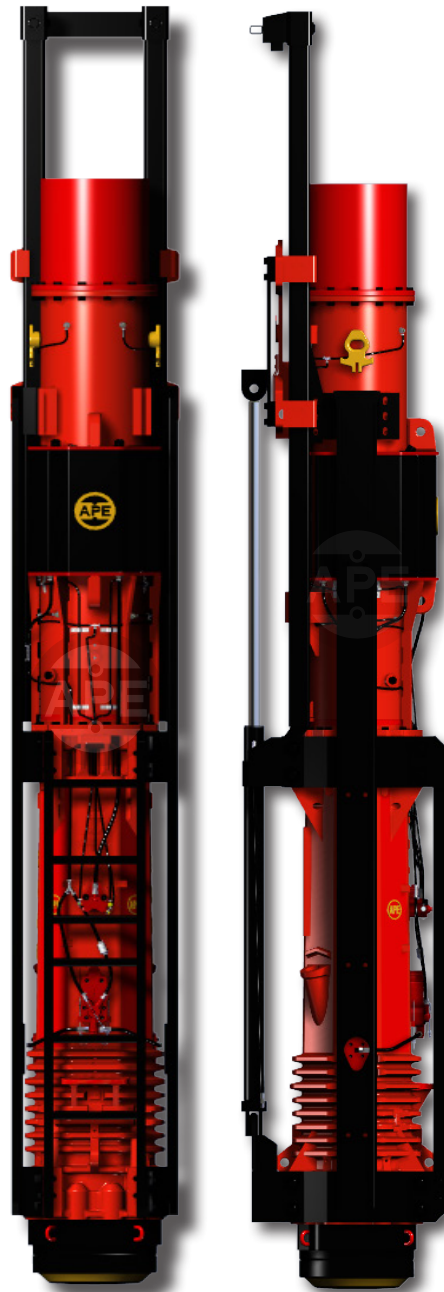

APE DIESEL HAMMER SPARE PARTS MANUAL

DEEP FOUNDATION SOLUTIONS



800-248-8498

WWW.AMERICANPILEDRIVING.COM

MODEL D46-52
D50-52

Copyright © 2022 American Piledriving Equipment Inc.

*All rights reserved, No part of this publication may be reproduced, distributed, or transmitted in any form of by any means, including photocopying, recording, or other electronic or mechanical methods, without prior written permission of the publisher. For permission requests, write to the publisher, addressed “**Attention: American Piledriving Equipment Manual Division**” at the address below.*

AMERICAN PILEDIVING EQUIPMENT, INC.

7032 S. 196th Street

Kent, Washington 98032

Office: 253-872-0141

Toll Free: 800-248-8498

Fax: 253-872-8710

APE_Manuals@americanpiledriving.com



800-248-8498

WWW.AMERICANPIEDIVING.COM

MODEL D46-52 • D50-52

Copyright © 2022 American Piledriving Equipment Inc. All Rights Reserved

Quick Reference Guide

This Quick Reference Guide will assist you in finding the information you're looking for.

GENERAL INFORMATION

EQUIPMENT OVERVIEW

REFUSAL CRITERIA

REPLACEMENT PARTS

REFERENCE / NOTES

A Table of Contents is included after the Foreword.

Description:

MODEL D46-52 • D50-52 Diesel Hammer



WARRANTY INFORMATION

American Piledriving Equipment, Inc. (APE) warrants new products sold by it to be free from defects in material or workmanship for a period of two (2) years after the date of delivery to the first user and subject to the following conditions:

- APE's obligation and liability under this WARRANTY is expressly limited to repairing or replacing, at APE's option, any parts which appear to APE upon inspection to have been defective in material or workmanship. Such parts shall be provided at no cost to the user, at the business establishment of APE or the authorized APE distributor of the product during regular working hours.
- This WARRANTY shall not apply to component parts or accessories of products not manufactured by APE, and which carry the warranty of the manufacturer thereof, or to normal maintenance (such as engine tune-up) or normal maintenance parts (such as filters).
- Replacement or repair parts installed in the product covered by this WARRANTY are warranted only for the remainder of the warranty as if such parts were original components of said product.
- APE makes no other warranty, expressed or implied, and makes no warranty of merchantability or fitness for any particular purpose.
- APE's obligations under this WARRANTY shall not include any transportation charges, costs of installation, duty, taxes or any other charges whatsoever, or any liability for direct, indirect, incidental or consequential damage or delay.
- If requested by APE, products or parts for which a warranty claim is made are to be returned, transportation prepaid, to APE.

OIL MUST MEET ISO CLEANLINESS CODE 17/15/11. OIL THAT DOES NOT MEET CLEANLINESS CODE WILL **VOID** THE WARRANTY

ANY IMPROPER USE, INCLUDING OPERATION AFTER DISCOVERY OF DEFECTIVE OR WORN PARTS, OPERATION BEYOND RATED CAPACITY, SUBSTITUTION OF ANY PARTS WHATSOEVER, USE OF PARTS NOT APPROVED BY APE OR ANY ALTERATION OR REPAIR BY OTHERS IN SUCH A MANNER AS, IN APE'S JUDGMENT, AFFECTS THE PRODUCT MATERIALLY AND ADVERSELY, SHALL **VOID** THIS WARRANTY.

ANY TYPE OF WELDING ON APE'S EQUIPMENT WILL **VOID** THE WARRANTY UNLESS AUTHORIZED IN WRITING BY APE

NO EMPLOYEE IS AUTHORIZED TO CHANGE THIS WARRANTY IN ANY WAY OR GRANT ANY OTHER WARRANTY UNLESS SUCH CHANGE IS MADE IN WRITING AND SIGNED BY AN OFFICER OF APE, INC.

FOREWORD

This parts manual covers **APE Diesel Hammer** replacement information. This parts manual should be stored in a literature holder or literature storage area.

Some photographs or illustrations in this parts manual show details or attachments that may be different from your equipment. Continuing improvement and advancement of product design may have caused changes to your equipment which are not included in this manual. Whenever a question arises regarding your equipment, or this manual, please consult with your APE dealer for the latest available information.

Using this Parts manual:

- Refer to the Table of Contents for the page location of applicable sections.
- All weights and measurements are in English and Metric units.
- Please visit www.americanpiledriving.com for product data sheets and manuals and latest available information.

DISCLAIMER:

This unit was tested before leaving our facility. In order to help provide years of trouble-free usage, please review the following documentation and make sure to clean and flush the quick disconnect fitting on any equipment before connecting it to the power unit.

Refer to schematic diagrams and the BOM (Bill of Materials) for component part specifications and recommended spare parts.

When calling APE, always have the equipment serial number on hand in order to obtain quicker service.



TABLE OF CONTENTS

SAFETY SECTION	7
DIESEL HAMMER FEATURES & BENEFITS	12
LUBRICATION INSTRUCTIONS	14
WARNING LABELS.....	15
DIESEL PILE HAMMER D46-52 / D50-52	16
PISTON ASSEMBLY	18
CYLINDER LOWER PART ASSEMBLY	20
FUEL INJECTION DEVICE ASSEMBLY	22
VARIABLE DELIVERY FUEL PUMP ASSEMBLY.....	26
FUEL LINE / BREATHER LINE ASSEMBLY.....	28
LUBE PUMP ASSEMBLY	30
LUBE LINE WITH CONNECTING ASSEMBLY.....	32
CYLINDER UPPER PART ASSEMBLY.....	34
SET CONNECTING PART ASSEMBLY.....	36
TRANSPORT PROTECTION ASSEMBLY.....	38
TRIP GEAR COMPLETE.....	40
TOOLS AND ACCESSORIES	42
REFERENCE / NOTES.....	44



Safety Section

General Safety Precautions



DANGER indicates a hazardous situation which, if not avoided, will result in death or serious injury.



WARNING indicates a hazardous situation which, if not avoided, could result in death or serious injury.



CAUTION indicates a hazardous situation where injury could occur but is unlikely to be serious or lead to death.



NOTICE indicates information that may help or guide you in the operation or service of the equipment.

DISCLAIMER:

This unit was tested and flushed before leaving our facility. In order to help provide years of trouble free usage, please review the following documentation and make sure to clean and flush the field piping before connecting it to the power unit.

Refer to schematic diagrams and the BOM (Bill of Materials) for component part specifications and recommended spare parts.

When calling APE (American Piledriving Equipment), always inform them of the supplied serial # in order to obtain quicker service

NOTICE

READ THIS MANUAL THOROUGHLY BEFORE OPERATING AND / OR WORKING ON THE EQUIPMENT

1. Read and follow any safety instructions in the OPERATOR'S MANUAL.
2. Only well-trained and experienced personnel should attempt to operate or maintain this equipment.
3. NEVER adjust, lubricate and/or repair the unit when it is in operation or lifted above ground level.
4. NEVER remove, paint over and/or cover warning or safety labels. If labels become damaged or unreadable, replace immediately.
5. All personnel should wear approved safety clothing including HARD HATS, SAFETY SHOES, SAFETY GLASSES and HEARING PROTECTION when near this equipment.
6. Do **NOT** stand any closer to this equipment than necessary when it is in operation. Parts may loosen and fall. **NEVER** stand under operating or elevated equipment.
7. When maintaining and/or repairing the equipment, **NEVER** substitute parts not supplied or approved in writing by APE.

NOTICE

Do NOT weld or flame cut on this equipment.

8. NEVER use or store flammable liquids on or near the equipment.
9. Insure that all lifting equipment, including cranes, wire rope, slings, hooks, shackles, etc., are properly sized for the worst caseloads anticipated during operations.
10. If there are any questions about the weights, specifications and/or performance of the unit, contact APE before handling and/or operating the equipment.
11. Check wire rope clips for tightness and wire ropes for wear daily.
12. Insure that ground vibrations will not damage or collapse adjacent structures or excavations.

Safety Section



When operating in an enclosed area, exhaust fumes should be piped outside. Continued breathing of exhaust fumes may prove FATAL.

13. Remove all tools, parts and/or electrical cords before starting the unit.
14. When filling the fuel tank, do **NOT** smoke and/or use an open flame in the vicinity.
15. If abnormal equipment operation is observed, discontinue use immediately and correct the problem.
16. Store oily rags in approved containers and away from the engine exhaust system.
17. NEVER operate this equipment with hydraulic hoses that are damaged or 'kinked'. Replace damaged hoses immediately.
18. Do **NOT** lift and/or support hydraulic hoses with wire rope slings.
19. NEVER attempt to connect Quick Disconnects (QDs) when the Power Unit is running.
20. Do **NOT** pull on and/or attempt to move equipment with the hydraulic hoses.
21. Do **NOT** attempt to locate hydraulic leaks with your hands. High-pressure leaks can penetrate skin and cause severe damage, blood poisoning and/or infection.
22. Do **NOT** attempt to repair leaks while the equipment is in operation.
23. Do **NOT** attempt to tighten and/or loosen fittings and/or hoses when the machine is in operation.
24. Power Unit must always be placed on level, stable ground.
25. Do **NOT** remove Power Unit heat shields. Do NOT attempt to use the Power Unit without heat shields. Severe fires may result.

NOTICE

A properly maintained fire extinguisher, suitable for oil fires, MUST be kept in the immediate vicinity of equipment operations.

26. When moving and/or transporting this equipment, insure that the vehicle and/or vessel is of sufficient capacity to handle the load. Make sure that the equipment is properly tied down.
27. When moving and/or transporting this equipment, be sure that the QD Dust Caps are tight and that the cap safety cables are in place. Be sure that all equipment parts are tight and/or properly secured before shipment. Unsecured parts may vibrate loose and fall during transport causing injury and/or property damage.
28. Rounded and/or damaged bolt heads and/or nuts should be replaced so that proper torque values may be obtained. Proper torque values are necessary to prevent parts on this equipment, leads and/or crane booms from loosening and/or falling. (Refer to the torque chart in this manual for the proper values.)
29. When operating in a closed area, pipe exhaust fumes outside. (**Warning:** Breathing exhaust fumes can cause serious injury or even death.)
30. If diesel hammer is equipped with a Power unit, When loading or unloading the power unit using a forklift, the forks must be placed under the entire depth of the unit.
31. Never stand under an equipment at any time and keep your eyes on the equipment when it is in operation.

SAFETY MESSAGES

There may be several specific safety messages on your equipment. The exact location and description of the safety messages are reviewed in this section. Become familiar with all safety messages.

Ensure that all the safety messages are legible. Clean the safety messages or replace the safety messages if the words cannot be read or if the illustrations are not visible. Use a cloth, water and soap to clean the safety messages. Do not use solvents, gasoline, or other harsh chemicals. Solvents, gasoline, or harsh chemicals could loosen the adhesive that secures the safety messages. The safety messages that are loosened could drop off the equipment.

Replace any safety message that is damaged or missing. If a safety message is attached to a part of the equipment that is replaced, install a new safety message on the replacement part. Your APE dealer can provide new safety messages.



Do not operate or work on this equipment unless you have read and understand the instructions and warnings in the Operation and Maintenance Manual. Failure to follow the instructions or read the warnings could result in injury or death. Contact any APE dealer for replacement manuals. Proper care is your responsibility.

DO NOT WELD



Do **NOT** weld on or around the power unit unless authorized in writing by APE. Doing so will void all warranties and may cause damage to the power unit or vibro.

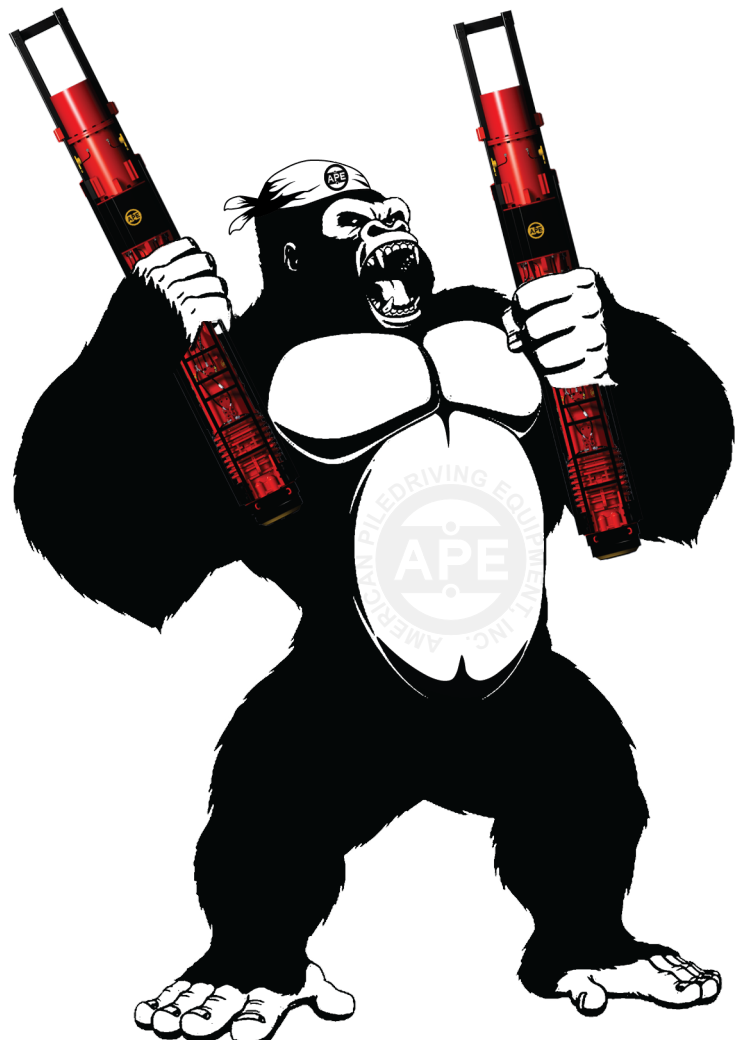

GENERAL HAZARD INFORMATION



Attach a “Do Not Operate” warning tag to the start switch or controls before the equipment is serviced or repaired. Attach the warning tags to the engine and to each operator control panel. When appropriate disconnect the negative terminal on the battery.

Do not allow unauthorized personnel on the equipment or around the equipment while being serviced.

Cautiously remove the following parts. To help prevent spraying or splashing of pressurized fluids hold a rag over the part that is being removed.

- Filler caps
- Grease fittings
- Pressure taps
- Breathers
- Drain plugs

PRESSURIZED AIR AND WATER

Pressurized air and/or water can cause debris and/or hot water to be blown out which could result in personal injury.

The maximum air pressure for cleaning purposes must be reduced to 30psi (205 kPa) when the air nozzle is deadheaded and used with effective chip guarding (if applicable) and personal protective equipment. The maximum water pressure for cleaning purposes must be below 40psi (275 kPa). When pressurized air and/or pressurized water is used for cleaning, wear protective clothing, protective shoes, and eye protection. Eye

protection includes goggles or a protective face shield. Always wear eye protection for cleaning the cooling system.

Avoid direct spraying of water on electrical connectors, connections, and components. When using air for cleaning, allow the equipment to cool to reduce the possibility of fine debris igniting when redeposited on hot surfaces.

FLUID PENETRATION

Always use a board or cardboard when you check for a leak. Leaking fluid that is under pressure can penetrate body tissue. Fluid penetration can cause serious injury and possible death. A pin hole leak can cause severe injury. If fluid is injected into your skin, you must get medical treatment immediately. Seek treatment from a doctor that is familiar with this type of injury.

CONTAINING FLUID SPILLAGE

NOTICE

Care must be taken to ensure that fluids are contained during performance of inspection, maintenance, testing, adjusting, and repair of the equipment. Be prepared to collect the fluid with suitable containers before opening any compartment or disassembling any component containing fluids. Dispose of all fluids according to local regulations and mandates.

LINES, TUBES, AND HOSES

Do not bend or strike high-pressure lines. Do not install lines, tubes, or hoses that are damaged. Repair any fuel lines, oil lines, tubes, or hoses that are loose or damaged. Leaks can cause fires or injury. Inspect all lines, tubes, and hoses carefully. Do not use bare hands to check for leaks. Always use a board or cardboard for checking equipment components for leaks. Tighten all connections to the recommended torque.

Safety Section

Check for the following conditions:

- End fittings that are damaged or leaking
- Outer covering that is chafed or cut
- Wire that is exposed in reinforced hose
- Outer covering that is ballooning locally
- Flexible part of the hose that is kinked or crushed
- Armoring that is embedded in the outer covering

Ensure that all of the clamps, guards, and heat shields are installed correctly. Correct installation of these components will help to prevent these effects: vibration, rubbing against other parts and excessive heat during operation.

INHALATION

Exhaust fumes can be hazardous to your health. If you operate the equipment in an enclosed area, adequate ventilation is necessary,

BURN PREVENTION

Do not touch any part of the equipment during operation. Allow the equipment to cool before any maintenance is performed on the engine. Relieve all pressures in the hydraulic system, fuel system, lubrication system, or cooling system before any lines, fittings, or related items are disconnected.

OIL

Hot oil and hot components can cause personal injury. Do not allow hot oil or hot components to contact the skin.

Keep all of the exhaust manifold and turbocharger heat shields in place in order to protect components from oil spray if there is a failure of a line, tube, or seal.

CRUSHING PREVENTION AND CUTTING PREVENTION

Support the equipment properly when work beneath the equipment is performed.

Unless other maintenance instructions are provided never attempt adjustments while the engine is running. Stay clear of all rotating parts and moving parts. Leave the guards in place until maintenance is performed. After the maintenance is performed reinstall the guards.

Keep objects away from moving fan blades. The fan blades will throw objects or cut objects. Wear protective glasses in order to avoid injury to the eyes. Chips or other debris may fly off objects when objects are struck. Before objects are struck, ensure that no one will be injured by flying debris.

MOUNTING AND DISMOUNTING

Do not climb on the equipment, and do not jump off the equipment. Do not stand on the components which can not support your weight. Mount the equipment and dismount the equipment only at locations that have a ladder or handholds.



Diesel Hammer Features & Benefits

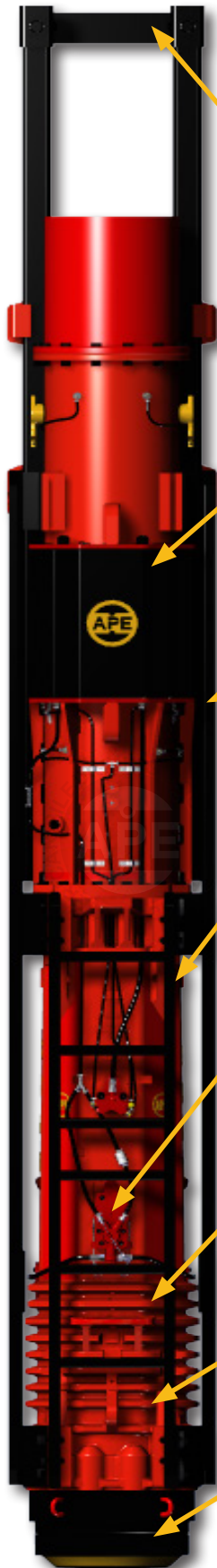

Bolt on Trip Stop allows for quick trip removal.

Increased fuel and lube tank capacity which allows for extended use of hammer.

Full Length Heavy Duty hammer lead guides with three point bolted connection for added strength.

Removable pump guard.

Fuel pump with four step adjustment

The Octagon shaped lower cylinder provides additional strength to the housing and dissipates heat more evenly which allows for longer run times.

The NEW 52 series Octagon style lower cylinder is interchangeable between the older 32 and 42 series hammers.

Rebound Ring

Diesel Hammer Features & Benefits

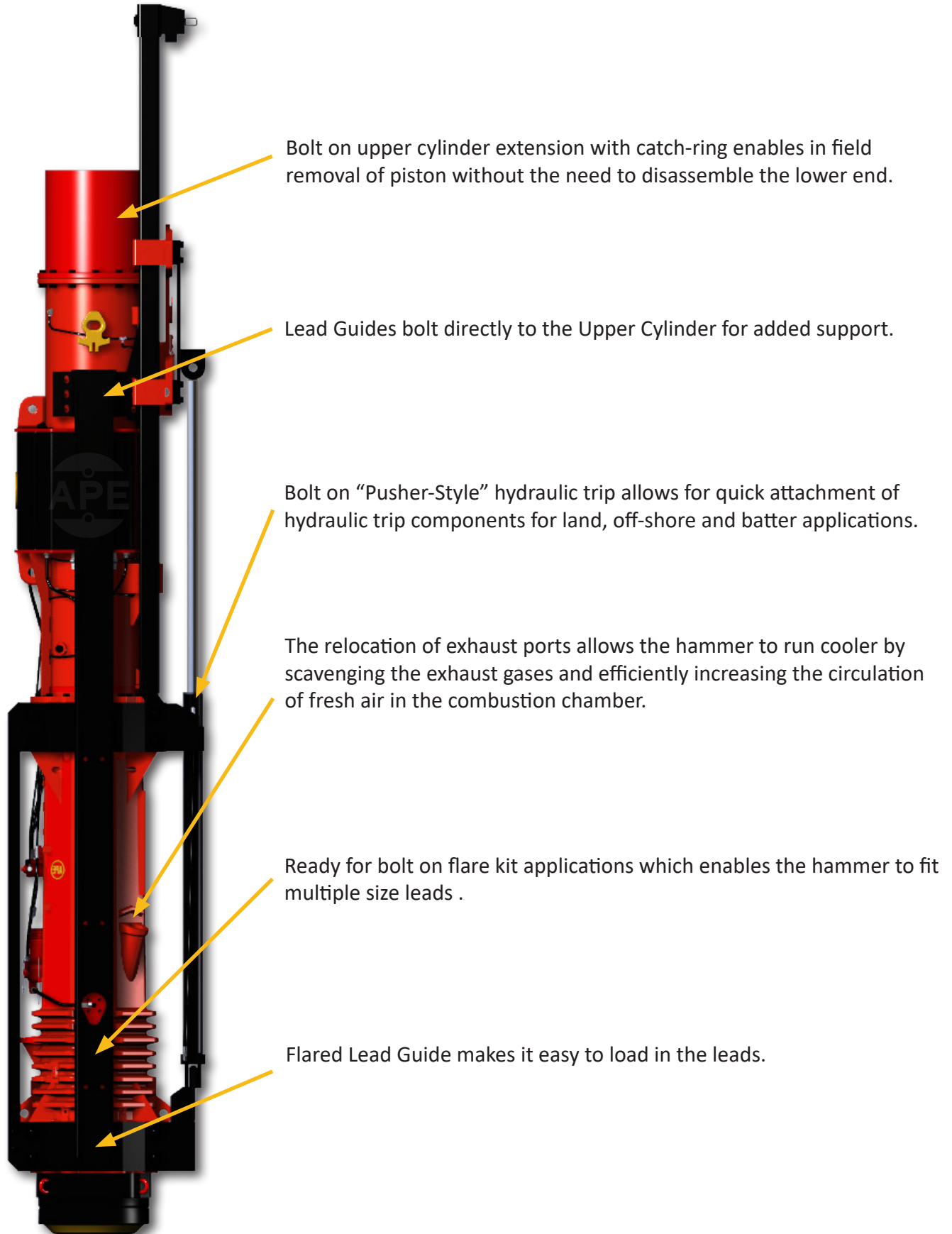

Lubrication Instructions



LUBRICATION INSTRUCTIONS

Call APE at 253-872-0141 or your nearest APE branch location.
Visit our website at www.americanpiledriving.com for free training CD's.

WARNING: Do not use general purpose grease like that used to lubricate crane parts. Use high temperature moly graphite type grease only. Improper grease will burn & seize up the piston rings and cause hammer to lose compression. A loss in compression can cause increased ram velocity at impact which may mushroom the end of the piston.

DAILY COMPRESSION CHECK

Dry fire hammer by tripping hammer while fuel is shut-off. Piston should strike anvil & then bounce upwards then slowly settle down onto top of anvil. Count the seconds it takes for the piston to stop bouncing from compression. If less than 10 seconds is recorded, then re-ring the hammer. Check for bore cylinder sleeve damage. Call APE for a free checklist of steps to take when rebuilding a diesel hammer.

GREASING INSTRUCTIONS

Grease lower impact block area every 20 minutes of driving time. Never grease the lower part of the hammer while anvil is sticking out or you will inject grease into the hammer cylinder.

CHECKING LUBE PUMP

If lube pump is not pumping oil, the ram will appear dry. Dump 2-cycle motor oil on top of piston to aid in lubrication. When time permits, remove lube pump & check wear parts for damage. All APE lube pumps are self-bleeding & do not need priming. A very metallic looking piston means the lube pump is not working properly. A dark oil piston or ram with oil dripping off the hammer is a good indication that the oil pump is over-oiling. Too much oil may cause excessive smoke & premature ring wear.

Oil Type: This diesel hammer is a 2-cycle engine. Use 2-stroke motor oil.

NEVER DRY FIRE A DIESEL HAMMER TO CLEAN THE COMBUSTION CHAMBER USE BLOW PLUG INSTEAD

Grease recommendations:

Bel Ray Molyube Extreme Pressure AC 2
Schaeffer Moly EP 274 Synthetic Plus

Oil recommendations:

Bel Ray Mc1 2 Cycle
Summer: Motor Oil SAE 40/50
Winter: Motor Oil SAE 20

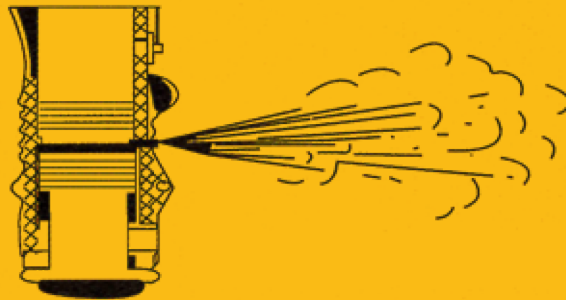

Note: Water can build up in the combustion chamber from rain or condensation. If not removed, this water can be forced up the injector & into the fuel pump or even the fuel tank. Water is the main source of downtime on a diesel hammer. Blow out your hammer each morning. Failure to do so will result in hard starting & irregular stroke. Never dry fire a hammer to remove unwanted water or oil.

ADDITIONAL WARNING: While wearing eye protection, each morning, prior to driving piles, please remove the plug located on the lower cylinder at the main combustion area & dry fire the hammer to blow out unwanted fuel that may have built up overnight. Drop piston once or twice & then replace plug.

October 2021

Scan for more Diesel
Information



000133

Warning Labels

WARNING

**STANDARD REFUSAL IS CONSIDERED
10 BLOWS PER INCH.
MORE THAN 10 BLOWS WILL RESULT IN SERIOUS DAMAGE
TO THE PILEDIVING EQUIPMENT.
PLEASE CONSULT APE / J&M IF YOU HAVE ANY QUESTIONS.
800-248-8498**

UPDATED: 10/2015 000159

WARNING

**THE GREASE SHIPPED WITH THIS HAMMER HAS BEEN
SELECTED ESPECIALLY FOR DIESEL HAMMERS AFTER
EXTENSIVE RESEARCH & DEVELOPMENT.
THE HAMMER MUST BE GREASED AFTER EACH 20 MINUTES
OF RUNNING TIME. THE FAILURE TO DO SO WILL CAUSE
INTERNAL DAMAGE, IMPAIR OPERATION & VOID ANY
WARRANTIES.**

AMERICAN PILEDIVING EQUIPMENT, INC. 000102

**NO MORE
THAN 10
BLOWS
PER INCH**

000151

NOTICE

When operating the hammer, do not exceed 10 blows per inch or 120 blows per foot. In cases of setting of the pile it is permitted to increase the blow count to 250 blows per foot, but for no more than one foot of driving penetration. Pile inspectors should consult the APE factory for permission to exceed these limits. Failure to do so will void the warranty.



Diesel Pile Hammer D46-52 / D50-52

REPLACEMENT PARTS

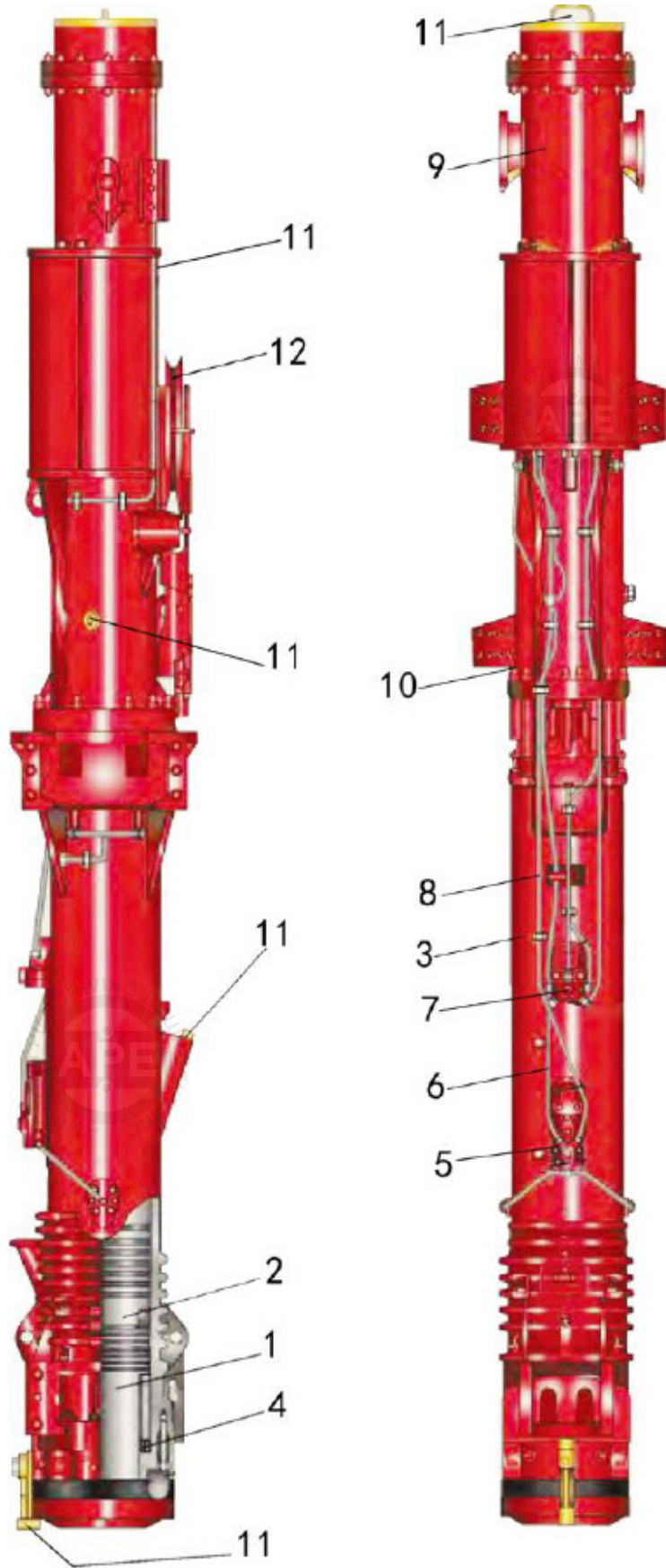

Diesel Pile Hammer D46-52 / D50-52

NO.	APE PART NUMBER	DESCRIPTION	QTY	REMARKS
-	9135.00	Diesel Hammer D46-52	1	D46
-	9175.00	Diesel Hammer D50-52	1	D50
1	135.08.00	Impact block assembly	1	
2	135.09.00	Striking Weight (Piston) for D46-52	1	D46
2	175.09.00	Striking Weight (Piston) for D50-52	1	D50
3	9135.01.00	Cylinder Lower Part Assembly For D46-52	1	D46
3	9175.01.00	Cylinder Lower Part Assembly for D50-52	1	D50
4	135.00-1	Inner Damping Ring	1	
5	135.02.00	Variable Delivery Fuel pump assembly	1	
6	135.11.00	Fuel Line/Breather Line assembly	1	
7	135.07.00	Lube Pump Assembly	1	
8	135.12.00	Lube line with connecting Assembly	1	
9	9135.03.00	Cylinder Upper Part Assembly	1	
10	135.06.00	Set Connecting Parts Assembly	1	
11	135.10.00	Transport Protecting Kit Assembly	1	
12	135.05.00	Trip Gear Assembly	1	
*	135.16.00	Tool Box Assembly	1	
*	135.14.00	Guide Clamp	4	
*	135.15.00	Guide Gib	4	
*	135.16.00	Tool Box Complete	1	

REPLACEMENT PARTS



Piston Assembly

REPLACEMENT PARTS

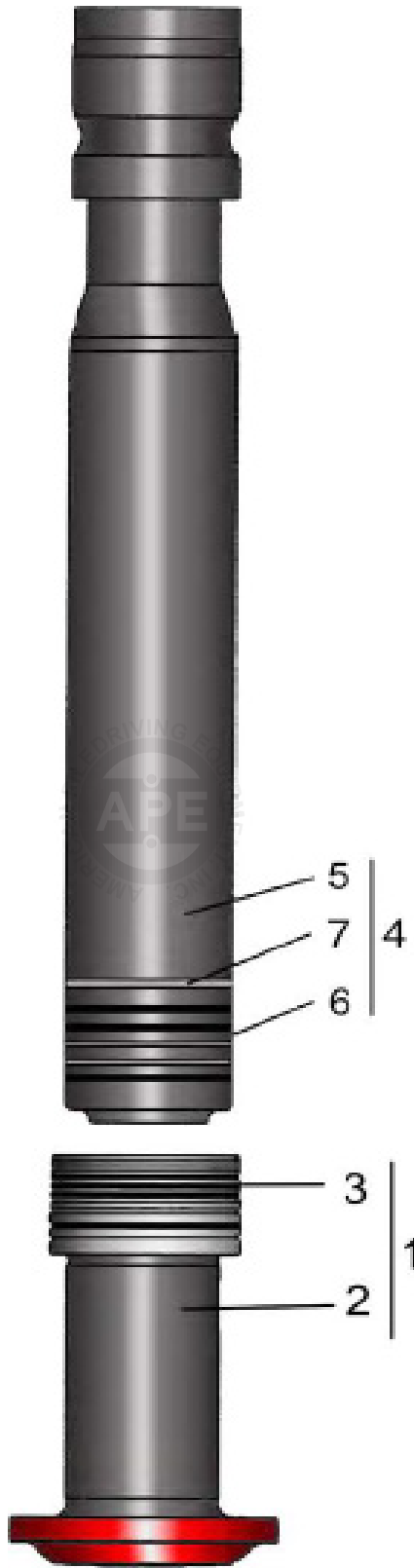

Cylinder Lower Part Assembly

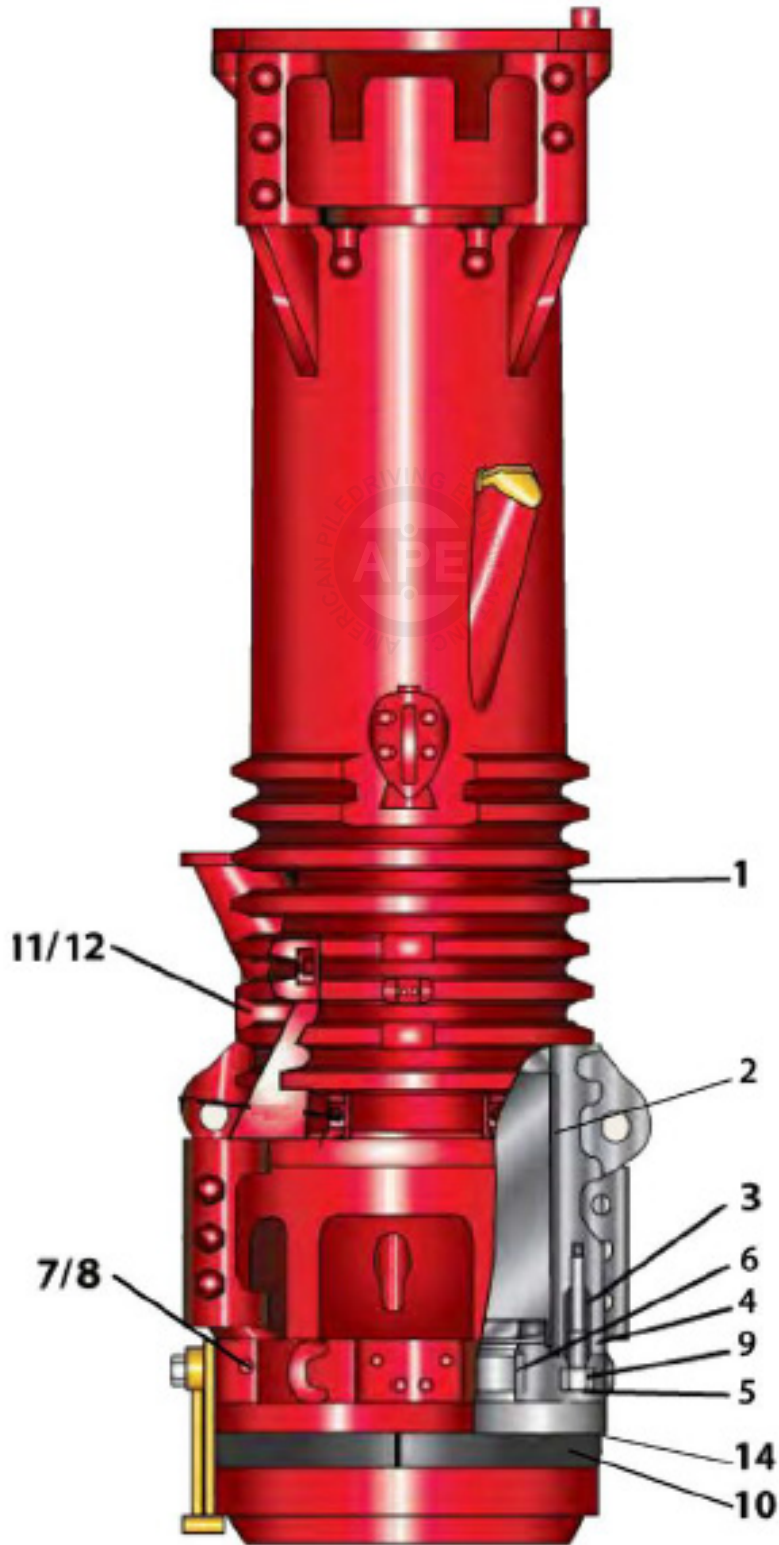

REPLACEMENT PARTS



Cylinder Lower Part Assembly

NO.	APE PART NUMBER	DESCRIPTION	QTY	REMARKS
-	9135.01.00	Cylinder Lower Part Assembly for D46	1	D46
-	9175.01.00	Cylinder Lower Part Assembly for D50	1	D50
1	9135.01.01	Cylinder Lower Part	1	D46
1	9175.01.01	Cylinder Lower Part	1	D50
2	135.01.01-1	Cylinder Sleeve	1	
2	135.01.01-2	Cylinder Sleeve	1	
3	135.01.01-3	Threaded Insert M24	24	
4	135.06.00-4	Dowel Pin 40 x 75	8	D46
4	175.06.00-4	Dowel Pin	8	D50
5	135.01.02.01	Cylinder End Ring 2 Piece Assembly	1	D46
5	175.01.02.01	Cylinder End Ring 2 piece Assembly	1	D50
6	135.01.02-1	Ring 2 piece	1	
7	135.01.02-2	Reducer	2	
8	135.01.02.02A	Grease Nipple M10x1	2	
9	135.06.00-2	Reduced Screw M24	16	D46
9	175.06.00-2	Reduced Screw M30	16	D50
10	131.01.00-1	Rubber Ring 2 Piece	1	
11	JB1000-1987	Plug Screw M1 8 x 1.5	1	
12	135.01.00-2	Sealing Ring A 18 x 22	1	
14	131.01.00-5	Sealing Ring	1	

REPLACEMENT PARTS



Fuel Injection Device Assembly

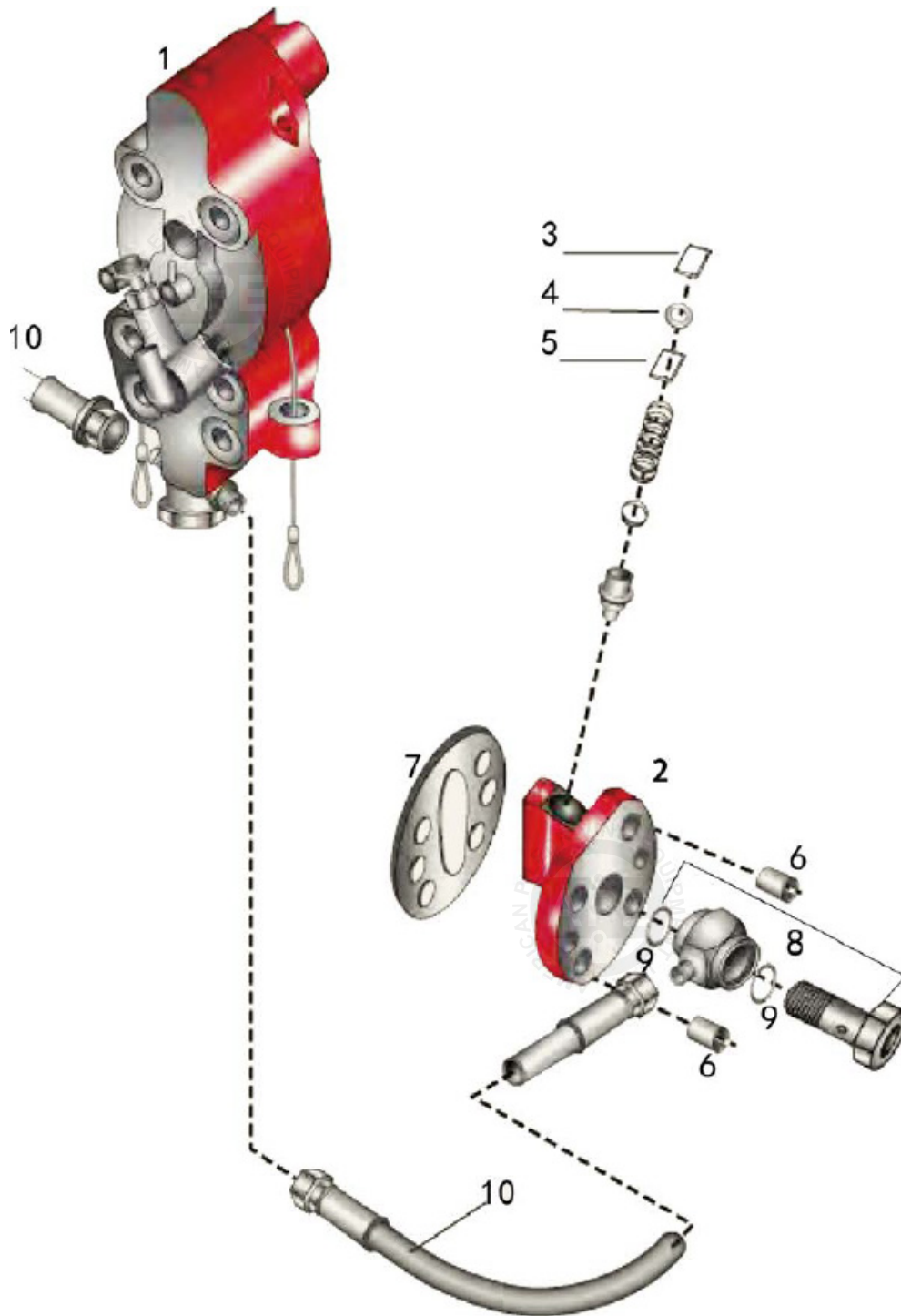

REPLACEMENT PARTS

Fuel Injection Device Assembly

NO.	APE PART NUMBER	DESCRIPTION	QTY	REMARKS
-		Variable-Delivery Fuel Pump	2	
1	135.02.00	Variable Delivery Fuel Pump assembly	2	
2	135.02.07	Injection Valve Assembly	2	
	135.02.07-1	Injection Valve Body	2	
3	135.02.07-3	Locking Plate	2	
4	135.02.07-2A	Disk Spring	2	
5	135.02.07-3	Locking Plate	2	
-	135.02.07-4	Valve Piston	2	
-	135.02.07-5	Pressure Spring	2	
-	135.02.07-7	Adjusting Washer	4	
6	135.02.00-27	Dowel Pin 21 x 28	4	
7	135.02.00-28	Sealing	2	
8	135.02.00-26	Threaded Pipe Joint	2	
-	135.02.00-23	Hollow Screw	2	
9	135.02.00-32	Round Sealing Ring 17 x 1.5	4	
10	132.02.08A	High Pressure Hose Line	2	

REPLACEMENT PARTS



Fuel Injection Device Assembly

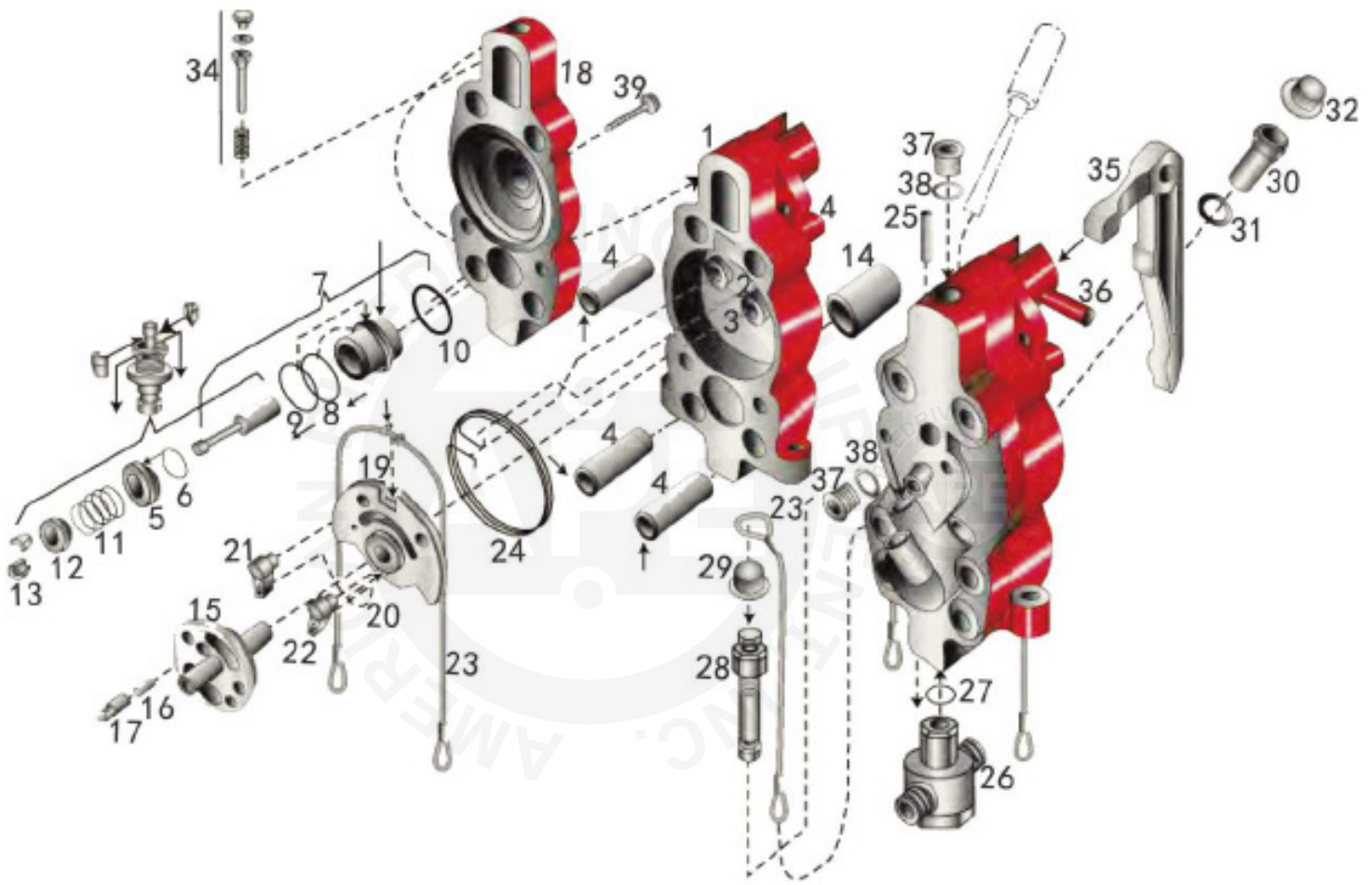

REPLACEMENT PARTS

NO.	APE PART NUMBER	DESCRIPTION	QTY	REMARKS
-	135.02.00	Variable Delivery Fuel Pump	1	
1	135.02.05	Pump Body Complete	1	
2	GB/T879-1986	Dowel Pin 5 x 40	1	
3	GB/T879-1986	Dowel Pin 6 x 28	1	
4	135.02.00-25	Dowel Pin 28 x 80	4	
5	131.02.00-24	Holder Ring	1	
6	135.02.00-19	Rounding Sealing Ring 35 x 2.5	1	
7	132.02.03	Pump Element Complete	1	

Fuel Injection Device Assembly

NO.	APE PART NUMBER	DESCRIPTION	QTY	REMARKS
8	135.02.03-3	Round Sealing Ring 40 x 2.5	1	
9	135.02.03-2	Round Sealing Ring 47 x 2.5	1	
10	135.02.03-1	Round Sealing Ring 42 x 3	1	
11	135.02.00-20	Pressure Spring	1	
12	135.02.00-21	Spring Retaining Collar	1	
13	135.02.00-22	Conical Ring 2 Piece	1	
14	135.02.00-23	Guide Sleeve	1	
15	135.02.01	Switch Shaft	1	
16	135.02.00-11	Pressure Spring 5.5 x 20 x 1.2	1	
17	135.02.00-10	Screen Pin	1	
18	135.02.02	Pump Cover Assembly	1	
19	135.02.04	Rope Disc Assembly	1	
20	135.02.00-15	Spring	1	
21	135.02.00-14	Cam	1	
22	135.02.00-13	Cam	1	
23	135.02.11	Regulating Rope	2	
24	135.02.00-18	Swivel Spring	1	
25	GB/T879-1986	Dowel Pin 6 x 40	1	
26	135.02.06	Check non return valve assembly	1	
27	135.02.00-12	Round Sealing Ring 22 x 3	1	
28	135.02.10	Stop Valve Assembly	1	
29	135.02.00-31	Protecting Cap	1	
30	135.02.09	Suction Valve assembly	1	
31	135.02.00-29	Sealing Ring A20 x 24	1	
32	135.02.00-31	Protecting Cap	1	
34	-	Pressure Piece Assembly	1	
35	135.02.00-17	Pump Lever	1	
36	135.02.00-16	Pin	1	
37	JB1001-1977	Plug Screw M18 x 1.5	2	
38	135.02.00-1	Sealing Ring A18 x 22	2	
39	GB/T5782-1986	Screw M8 x 50	1	

REPLACEMENT PARTS



Variable Delivery Fuel Pump Assembly

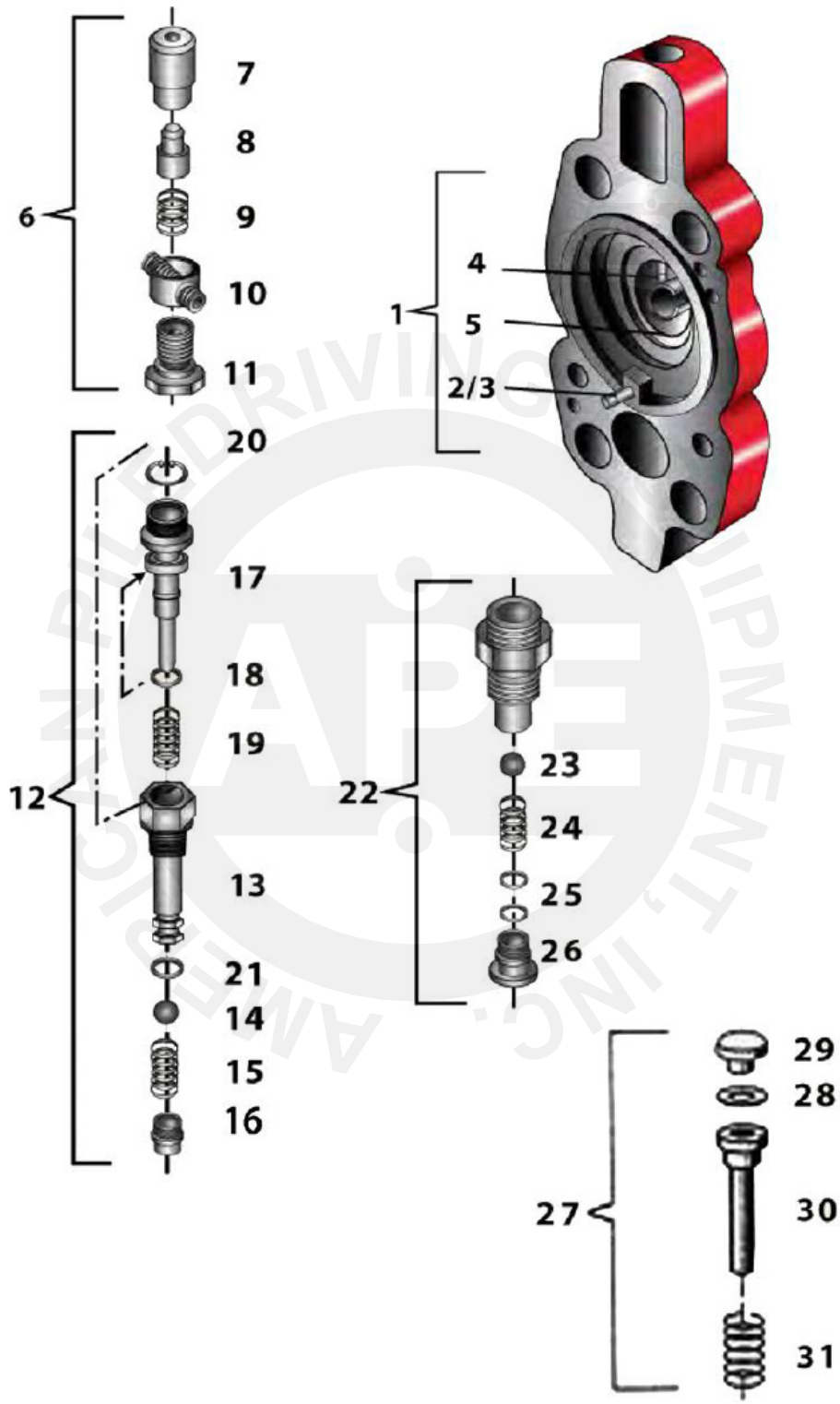

REPLACEMENT PARTS

Variable Delivery Fuel Pump Assembly

NO.	APE PART NUMBER	DESCRIPTION	QTY	REMARKS
-		Variable Delivery Fuel Pump Assembly	1	
1	135.02.02	Pump Cover Assembly	1	
2	GB/T879-1986	Dowel Pin 10 x 32	1	
3	135.02.02.01	Stop	1	
4	135.02.02-3	Stop Pin	1	
5	135.02.02-2	Ring	1	
6	132.02.06	Non-Return Valve Assembly	1	
7	135.02.06-1	Housing	1	
8	135.02.06-2	Valve Piston	1	
9	135.02.06-3	Pressure Spring	1	
10	135.02.06-4	Screw	1	
11	135.02.06-5	Ring Type Nipple	1	
12	135.02.10	Stop Valve Assembly	1	
13	135.02.10-7	Valve Screw	1	
14	GB/T308-1986	Ball ϕ 8.731mm	1	
15	135.02.10-5	Pressure spring	1	
16	135.02.10-4	Threaded Plug	1	
17	135.02.10-1	Valve	1	
18	135.02.10-6	Round Sealing Ring 8 x 3	1	
19	135.02.10-2	Pressure Spring	1	
20	GB/T893-1986	Cir-clip 20 x 1	1	
21	135.02.10-3	Round Sealing Ring 12 x 3	1	
22	135.02.09	Suction Valve Assembly	1	
*	135.02.09-1	Sleeve	1	
23	GB/T308-1986	Ball ϕ 8.731mm	1	
24	135.02.09-2	Pressure Spring 7.3 x 8 x 0.7	1	
25	135.02.09-3	Washer	2	
26	135.02.09-4	Threaded Plug	1	
27		Pressure Piece Assembly	1	
28	135.02.00-4	Adjusting Washer 8.2x19.8x0.3	1	
-	135.02.00-5	Adjusting Washer 8.2x19.8x0.5	1	
-	135.02.00-6	Adjusting Washer 8.2x19.8x0.6	1	
-	135.02.00-7	Adjusting Washer 8.2x19.8x0.4	1	
29	135.02.00-3	Push Cap	1	
30	135.02.00-9	Push Rod	1	
31	135.02.00-8	Pressure Spring 14.5x34x1	1	

REPLACEMENT PARTS



Fuel Line / Breather Line Assembly

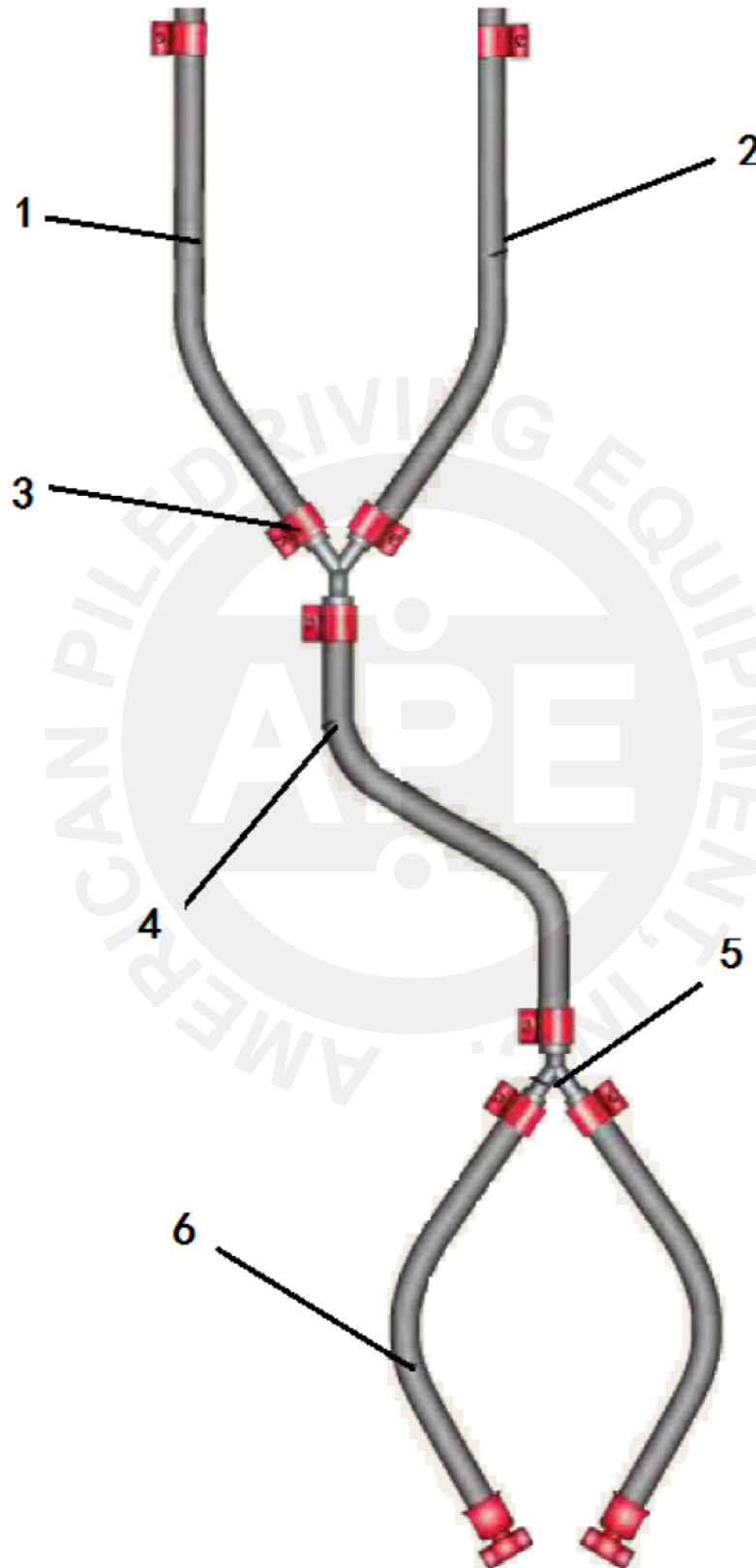

REPLACEMENT PARTS



Fuel Line / Breather Line Assembly

NO.	APE PART NUMBER	DESCRIPTION	QTY	REMARKS
-	131.11.00	Fuel Line/Breather Line Assembly	1	
1	135.11.00-5	Hose (0.48m long)	1	
2	135.11.00-4	Hose (0.8m long)	1	
3	No.0	Hose clip	8	
4	135.11.00-3	Hose (1.35m long)	1	
5	135.11.01A	Y-Hose Piece	2	
6	135.11.02	Hose (0.275m long)	2	

REPLACEMENT PARTS



Lube Pump Assembly

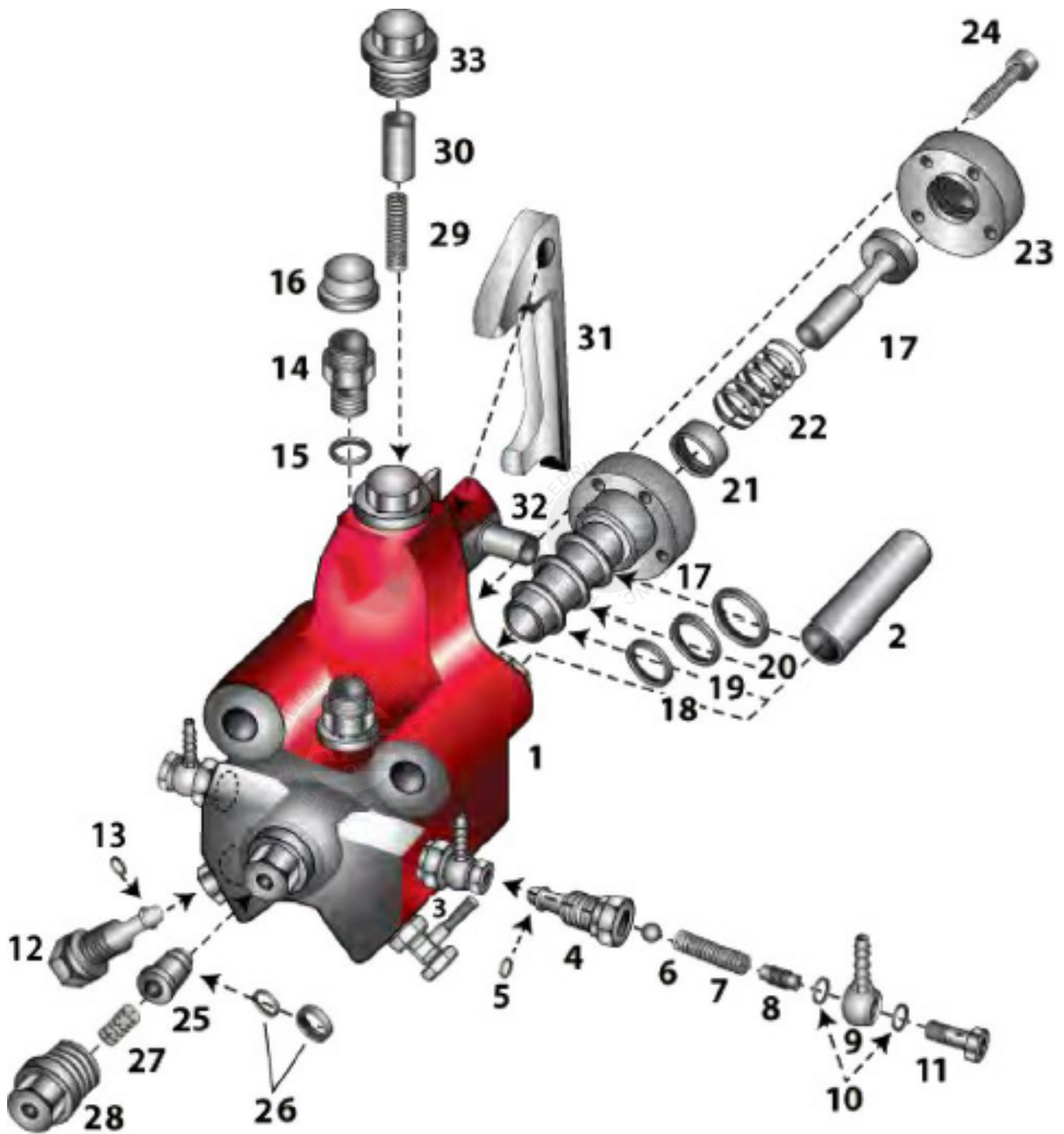

REPLACEMENT PARTS



Lube Pump Assembly

NO.	APE PART NUMBER	DESCRIPTION	QTY	REMARKS
-	135.07.00	Lube Pump Assembly	1	
1	135.07.00-7	Pump Body	1	
2	135.02.00-25	Dowel Pin 28x80 Din 7346	2	
3	135.07.03	Pressure Valve Assembly	3 set	
4	135.07.03-4	Adapter (Tube to Thread)	3x1	
5	135.07.03-7	Round Sealing Ring 8 x 2	3x1	
6	GB308-1989	Ball ϕ 6.000mm	3x1	
7	135.07.03-6	Pressure Switch 5 x 36 x 0.8	3x1	
8	135.07.03-5	Threaded Plug	3x1	
9	135.07.03-1	Ring Type Nipple	3x1	
10	JB982-77	Sealing Ring A12 x 15.5	3x2	
11	135.07.03-2	Hollow Screw A6	3x1	
-	135.07.04	Plug Screw Assembly	1 set	
12	135.07.04-1	Plug Screw	1x1	
13	135.07.03-7	Round Sealing Ring 8 x 2	1x1	
14	135.07.00-3	Adapter (Tube to Thread)	1	
15	135.02.00-29	Sealing Ring A20 x 24	1	
16	135.02.00-31	Protecting Cap	1	
17	135.07.01	Cylinder Assembly	1	
18	135.02.00-12	Round Sealing Ring 22 x 2	1	
19	135.07.01-4	Round Sealing Ring 26 x 3	1	
20	135.07.01-3	Round Sealing Ring 30 x 3	1	
21	135.07.00-9	Ring	1	
22	135.07.00-10	Pressure Spring 22 x 52 x 2.8	1	
23	135.07.00-11	Washer	1	
24	GB70-1985	Screw M8 x 35	4	
-	135.07.02	Piston Complete	1	
25	135.07.02-1	Piston	1	
26	135.07.02-2	Round Sealing Ring 12 x 2.5	1	
26	135.07.02-3	Slide Ring	1	
27	135.07.00-4	Pressure Spring 7.3 x 29.4 x 1.2	1	
28	135.07.00-5	Plug Screw	1	
29	135.07.00-8	Pressure Spring 10 x 43 x 2	1	
30	135.07.00-2	Sleeve	1	
31	135.07.00-6	Pump Lever	1	
32	135.07.00-1	Pin	1	
33	135.07.00-12	Plug Screw R1	1	

REPLACEMENT PARTS



Lube Line with Connecting Assembly

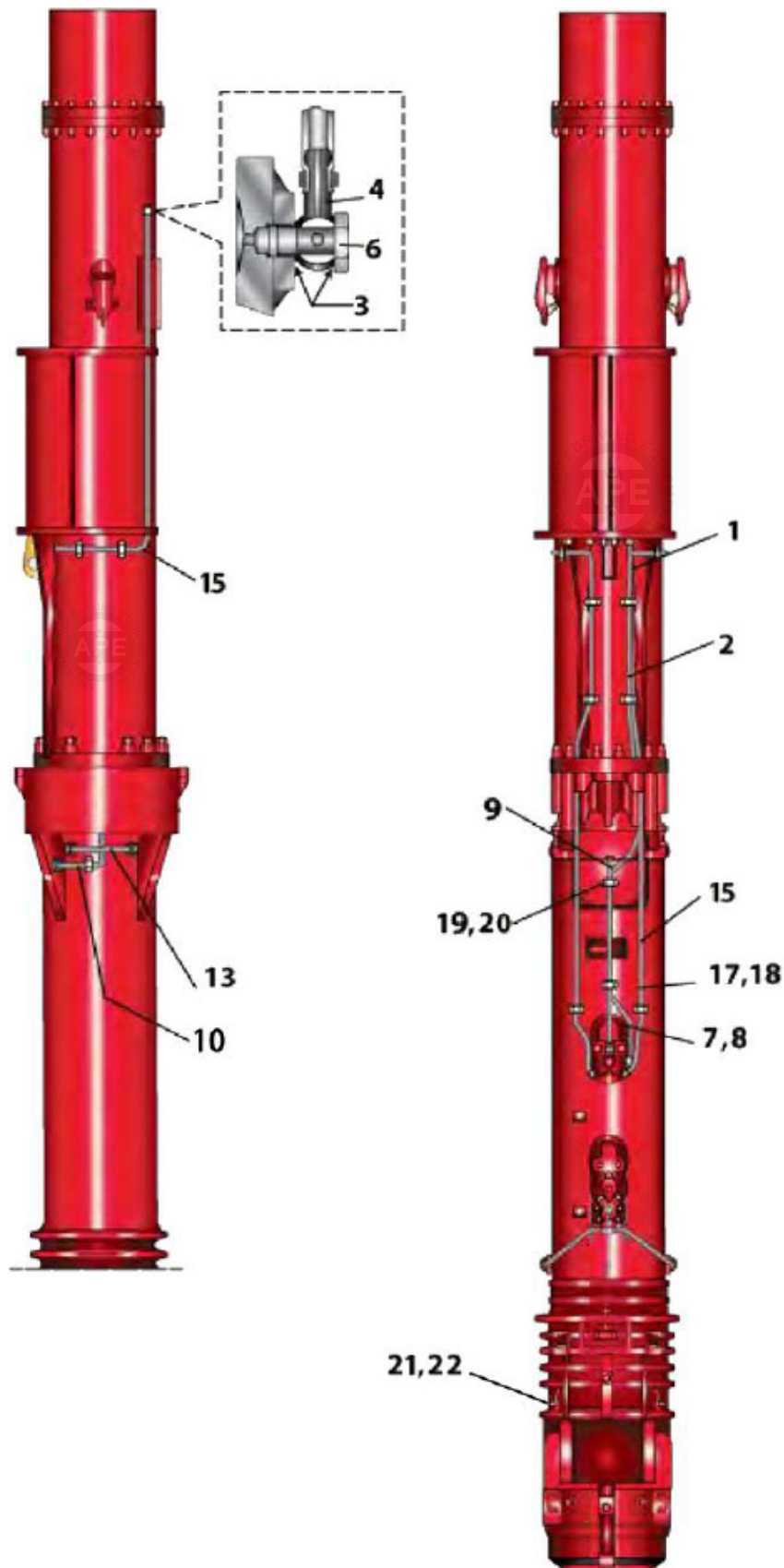

REPLACEMENT PARTS



Lube Line with Connecting Assembly

NO.	APE PART NUMBER	DESCRIPTION	QTY	REMARKS
-	135.12.00	Lube Line with Connecting Assembly	1	
1	135.12.01	Hose (1.6m long)	1	
2	No.0	Hose Clip 5/8"-1"	1	
3	JB982	Sealing Ring A12 x 15.5	8	
4	135.07.03-1	Ring Type Nipple	4	
6	135.07.03-2	Hollow Screw A6	4	
7	135.12.00-6	Hose (1.35m Long)	2	
8	No.000	Hose Clip 7/16" - 5/8"	12	
9	135.12.00-7	T-Piece	2	
10	135.12.00-4	Hose (0.56m Long)	1	
13	135.12.00-5	Hose (0.28m Long)	2	
15	135.12.00-3	Hose (4.05m Long)	1	
17	135.12.00-1	Hose Clip	16	
19	GB5782-86	Hexagon Headed Bolt M8 x 12	37	
20	GB93-87	Washer 8	37	
21	135.01.02-2	Reducer	4	
22	135.01.02.02A	Grease Nipple M10 x 1	4	

REPLACEMENT PARTS



Cylinder Upper Part Assembly

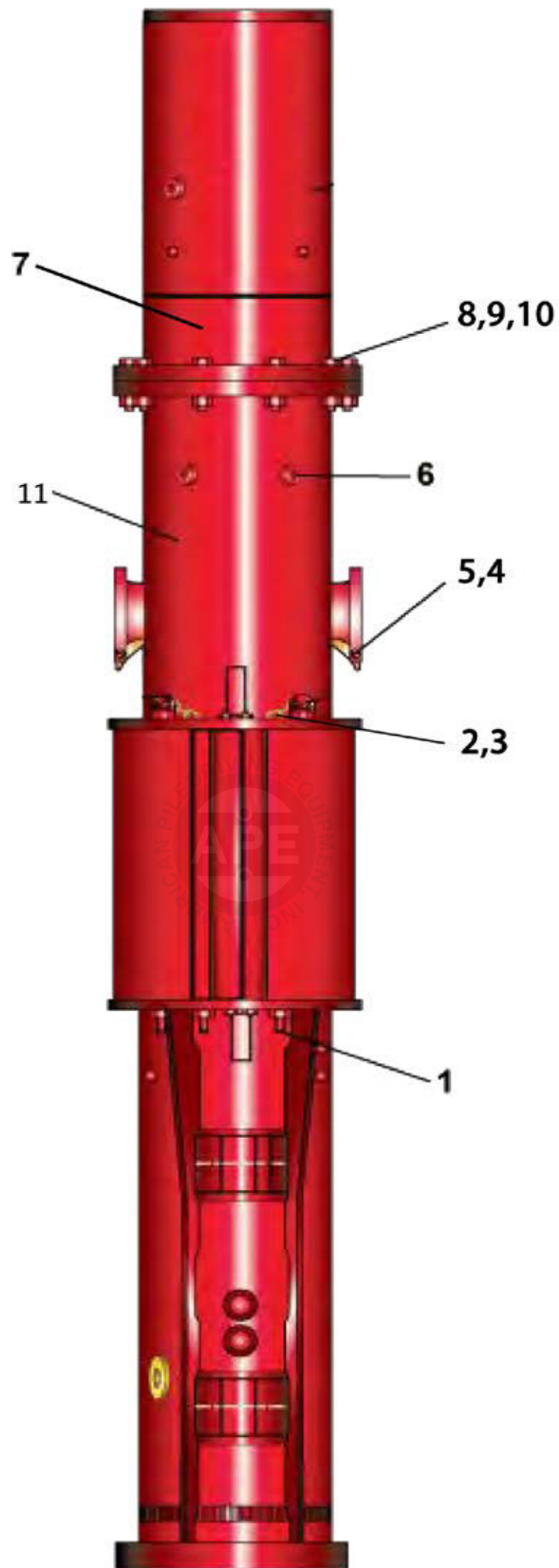

Cylinder Upper Part Assembly

NO.	APE PART NUMBER	DESCRIPTION	QTY	REMARKS
-	9135.03.00	Cylinder Upper Part Assembly	1	
1	135.03.02	Filter Elbow	3	
*	135.03.02-1	Screwed Joint	3	
*	135.03.02-2	Filter Element	3	
2	135.03.05	Plug Screw "Diesel"	1	
3	135.03.04	Plug Screw "Oil"	1	
4	135.03.00-3	Dowel Pin 13 x 60	2	
5	135.03.00-1	Ratchet	2	
6	135.01.02.02A	Grease Nipple M10 x 1	2	
7	131.3.1.3	Extend Cylinder	1	
7	133.18.00	Extended Cylinder	1	
8	GB/T5782-1986	Screw M24 x 110	8	
9	GB/T6185-1986	Nut M24	8	
10	GB/T93-1987	Washer 24	8	
11	9131.03.01	Cylinder Upper Part	1	
*	135.06.00-4	Dowel Pin 40 x 75	8	

REPLACEMENT PARTS



Set Connecting Part Assembly

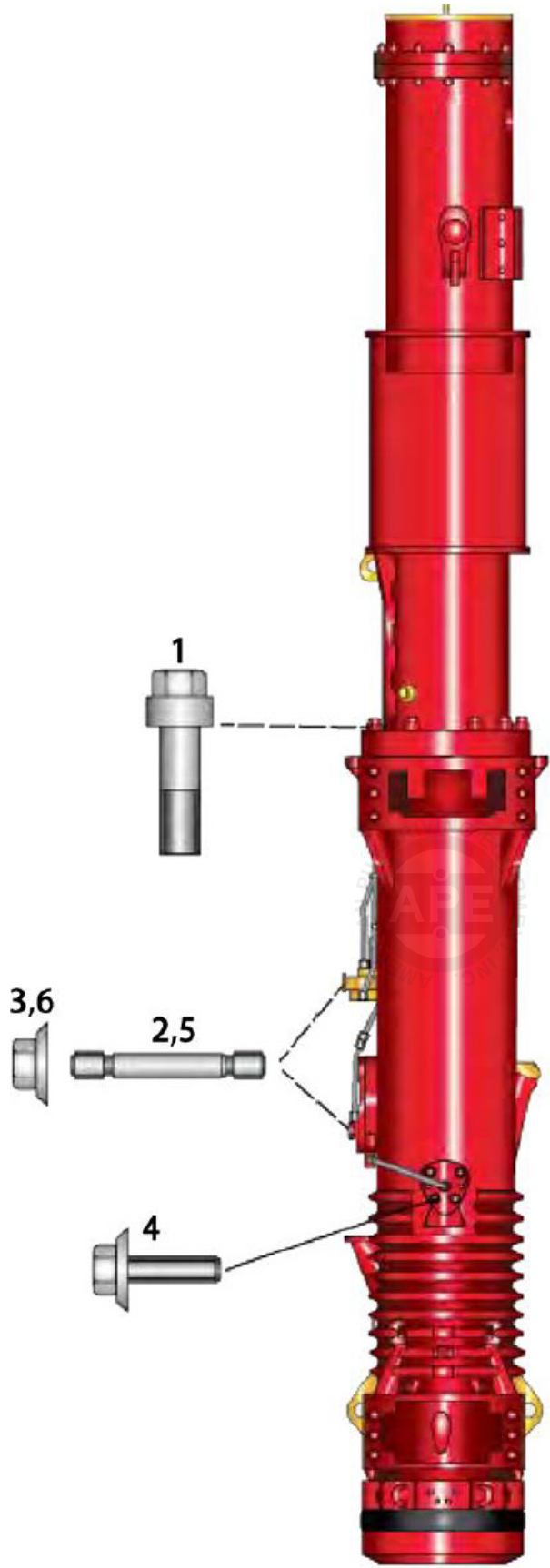

REPLACEMENT PARTS



Set Connecting Parts Assembly

NO.	APE PART NUMBER	DESCRIPTION	QTY	REMARKS
-	132.06.00	Set Connecting Parts Assembly	1	
1	135.06.00-2	Reduced Screw M24	12	
2	135.06.00-1	Stud Bolt M16	6	
3	135.06.00-5	Locking Nut M16	6	
4	135.06.00-6	Locking Screw M16 x 45	8	
5	135.06.00-1	Stud Bolt M16	2	
6	135.06.00-5	Locking Nut M16	2	
-		For Guide Clamp with lower cylinder part.		
*	135.06.00-4	Dowel Pin 40 x 75	8	
*	135.06.00-2	Reduced Screw M24	12	
-		For guide Clamps with lower cylinder part		
*	135.06.00-3	Screw M24 x 150	8	

REPLACEMENT PARTS



Transport Protection Assembly

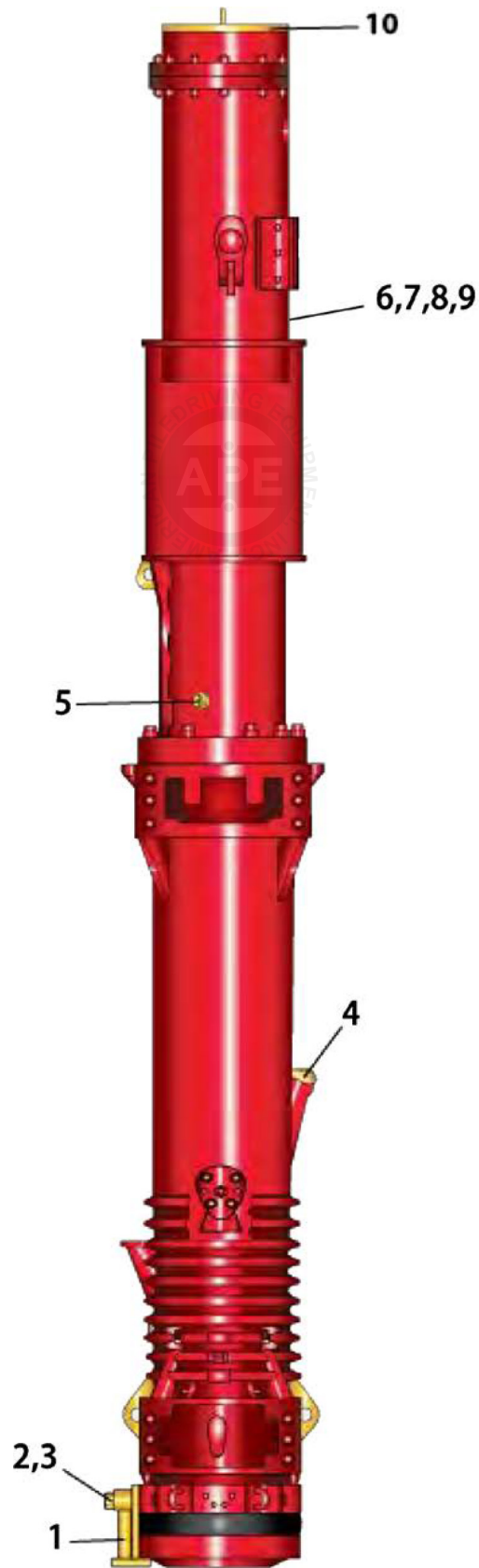

Transport Protection Assembly

NO.	APE PART NUMBER	DESCRIPTION	QTY	REMARKS
-	131.10.00	Transport Protection Assembly	1	
1	131.10.01.01A	Securing Clamp	1	
2	135.06.00-4	Dowel Pin 40 x 75	1	
3	135.06.00-2	Reduced Screw M24	1	
4	157.00-8	Exhaust Assembly	2	
5	132.10.00-1	Locking Screw M42 x 3	1	
-	135.10.02	Cylinder Slot Cover Assembly	1	
6	135.10.02.01	Cylinder Slot Cover	1	
7	135.10.02-02	Tommy Screw	1	
8	135.10.02-2	Star Handle	1	
9	GB/T879-1986	Dowel Pin 6 x 60	1	
10	131.10.03A	Protecting Cap	1	

REPLACEMENT PARTS



Trip Gear Complete

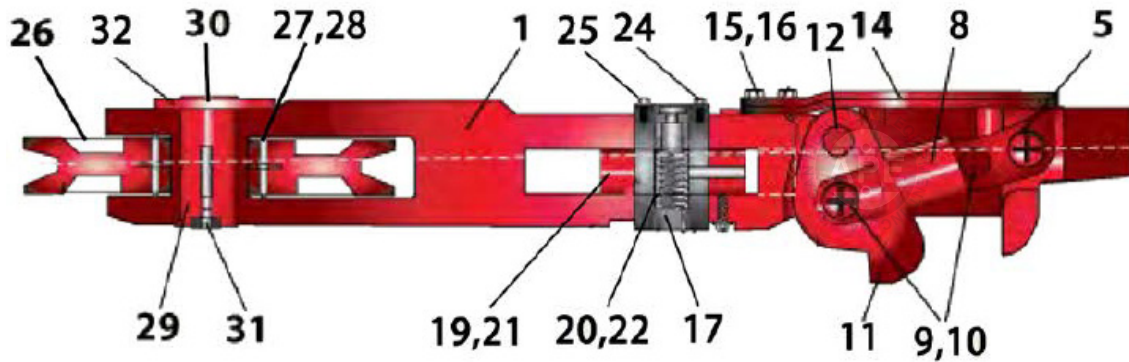
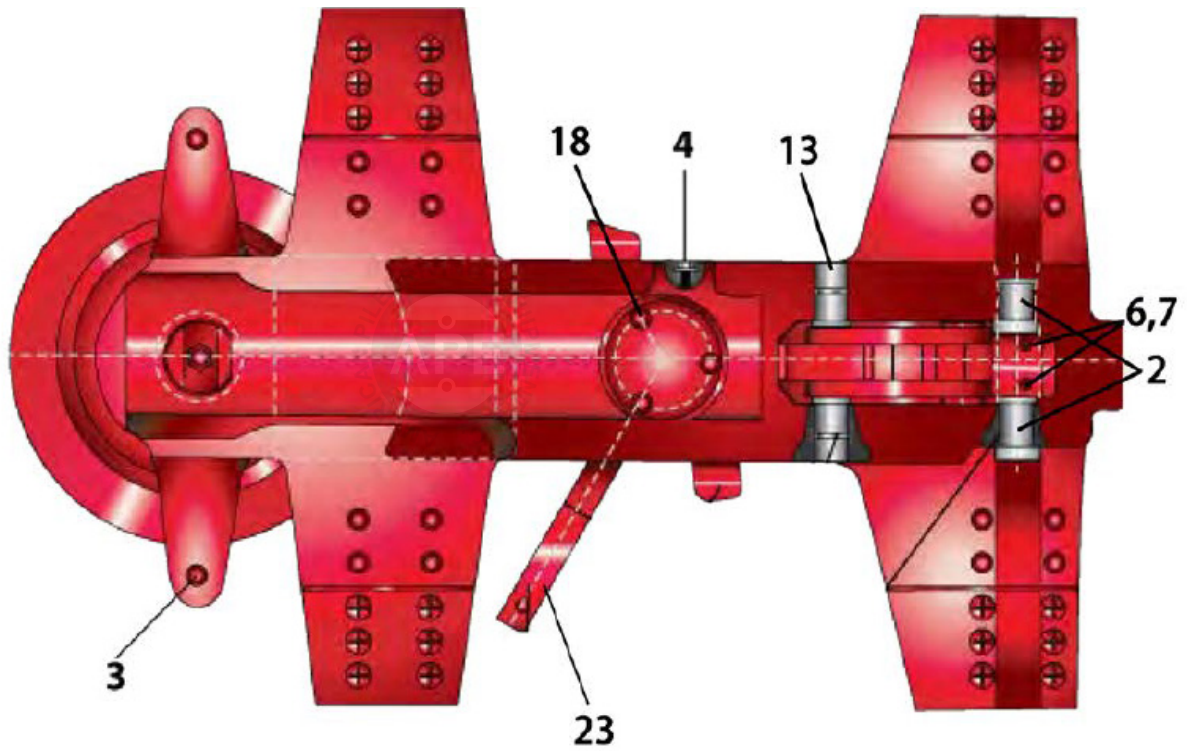

NO.	APE PART NUMBER	DESCRIPTION	QTY	REMARKS
-	135.05.00	Trip Gear Assembly	1	
1	135.05.00-6	Guide Body Assembly	1	
2	135.05.00-11	Sleeve	2	
3	135.05.00-15	Dowel Pin 25 x 140	2	
4	135.01.02.02A	Grease Nipple M10 x 1	2	

Trip Gear Complete

NO.	APE PART NUMBER	DESCRIPTION	QTY	REMARKS
5	135.05.03	Pawl Lever	1	
6	GB/T879-1986	Dowel Pin 8 x 80	2	
7	GB/T879-1986	Dowel Pin 13 x 80	2	
8	135.05.00-1	Shackle	2	
9	135.05.00-2	Joint Bolt	2	
10	135.05.00-13	Cir clip 45 x 1.75	4	
11	135.05.00-3	Pawl	1	
12	135.05.00-10	Pin	1	
13	GB/T879-1986	Dowel Pin 8 x 80	2	
14	135.05.00-9	Leaf Spring	2	
15	135.05.00-8	Plate	1	
16	135.05.00-14	Locking Screw M10 x 30	3	
17	135.05.00-5	Cover	1	
18	135.05.00-14	Locking Screw M10 x 30	3	
19	135.05.00-12	Carrier	1	
20	135.05.00-4	Shaft	1	
21	GB/T879-1986	Dowel Pin 16 x 70	1	
22	135.05.00-7	Torsion Spring	1	
23	135.05.02	Lever	1	
24	135.05.00-14	Locking Screw M10 x 30	3	
25	GB/T879-1986	Dowel Pin 10 x 32	1	
26	135.05.04A	Rope Pulley Complete	1	
*	135.05.04A-2	Rope Pulley	1	
27	GB/T292-1994	Bearing 36220	2	
28	135.05.04A-4	Pressure Plate	1	
*	GB/T93-1987	Washer 8	6	
*	GB/T5782-1986	Screw M8 x 20	6	
29	135.05.04A-1	Sleeve	2	
*	135.05.04A-3	Adjusting Ring	3	
30	135.05.01	Sheave Pin Complete	1	
-	135.01-1	Sheave Shaft	-	
31	135.01.02.02A	Grease Nipple M10 x 1	1	
32	GB/T91-1986	Split Pin 10 x 112	1	
*	135.05.05	Hoist Plate Complete	1	
*	-	Shackle 4.9	1	
*	GB/T5782-2000	Screw M24 x 65	6	
*	GB/T93-1987	Washer 24	6	

REPLACEMENT PARTS



Tools and Accessories



REPLACEMENT PARTS

Tools and Accessories

NO.	APE PART NUMBER	DESCRIPTION	QTY	REMARKS
-	136.16	Tools and Accessories	1	
1	132.16.01	Piston Ring Fitting Band	1	
2	135.16.02	Piston Ring Fitting Pliers	1	
*	135.16.03	Assembly Plate	2	
*	135.16.04-4	Pin Sheave	1	
8	135.16.04-5	Punch 12 / 16	1	
9	135.16.04-6	Punch 4 / 8	1	
10	135.16.04-7	Single-Head Spanner	1	
11	135.16.05	Tool Box	1	
12	-	Rope 35m long	2	
13	-	Rope 70m long	1	
14	2350-20/36DWN29	Ratchet Spanner	1	
15	GB/T825-1988	Ring Screw M48	1	
*	GB/T8918-1996	Cable wire 3M	2	
*	GB/T5976-1986	Cable Clamp	10	
18	GB/T879-1986	Dowel Pin 13 x 80	2	
19	GB/T879-1986	Dowel Pin 8 x 80	2	
20	GB/T879-1986	Dowel Pin 3 x 16	1	
21	GB/T4388-1995	Double Ended Open Spanner 30x32	1	
22	GB/T4388-1995	Double Ended Open Spanner 19x22	1	
23	GB/T4388-1995	Double Ended Open Spanner 22x24	1	
24	GB/T4388-1995	Single Ended Open Spanner 36	1	
25	GB/T4388-1995	Single Ended Open Spanner 27	1	
26	GB/T4388-1995	Single Ended Open Spanner 17	1	
27	GB/T4388-1995	Double Ended Ring Spanner 22x24	1	
28	GB/T4388-1995	Double Ended Ring Spanner 17x19	1	
29	GB/T3390-1989	Socket Wrench SW36	1	
30	GB/T5356-1998	Angled Screw Driver 5	1	
31	GB/T5356-1998	Angled Screw Driver 6	1	
32	GB/T5356-1998	Angled Screw Driver 8	1	
*	GB/T5356-1998	Angled Screw Driver 19	1	
35	-	Pliers A19	1	
*	-	Oil Feeder 180ml	1	
38		Extended/Extension Bar	1	
39	135.16.06	Grease Gun	1	

REPLACEMENT PARTS



REFERENCE / NOTES

RECOMMENDED BOLT TIGHTENING TORQUE “LUBRICATED SHCS”

Socket Head Cap Screws

When installing any APE equipment or parts apply lubricant and use APE standard **Anti-Seize** torque specs.
See Tightening Torque Spec below. Failure to follow tightening torque spec can result in under / over tightening fasteners, leading to equipment failure or personal injury.



COARSE THREADS

Nominal Screw Size	Nominal Socket Size	Tightening Torque (ft-lbs)
#10-24	5/32	6
.25-20	3/16	10
.31-18	1/4	22
.38-16	5/16	38
.44-14	3/8	61
.50-13	3/8	93
.63-11	1/2	179
.75-10	5/8	317
.88-9	3/4	511
1.00-8	3/4	767
1.25-7	7/8	1,533
1.50-6	1	2,668

FINE THREADS

Nominal Screw Size	Nominal Socket Size	Tightening Torque (ft-lbs)
#10-32	5/32	6
.25-28	3/16	12
.31-24	1/4	24
.38-24	5/16	43
.44-20	3/8	68
.50-20	3/8	105
.63-18	1/2	202
.75-16	5/8	354
.88-14	3/4	564
1.00-12	3/4	860
1.25-12	7/8	1,697
1.50-12	1	3,001

RECOMMENDED ANTI-SEIZE LUBRICANT

BENEFITS & FEATURES

- **Excellent Anti-Seize** Prevents seizing caused by galling, galvanic action, fretting, fusion, pitting, thread distortion, breakage, rust, and corrosion.
- **Water Resistant** Provides long term protection with just one application, outdoors or indoors, even in the damp areas or against salt spray. Will not wash off.
- **Wide Temperature Range** Coating withstands temperatures of -65 Degree F to 2100 Degree F. (-54 C to 1100 C)
- **Stable Coating** Will not harden or fuse to metal, cake, evaporate or separate
- **Compatible with many materials** Can be used as an anti-seize on the threads of steel, stainless steel, steel alloy, cast iron, aluminum, copper brass, and titanium parts and reduces friction and wear on plastic.
- **Environmentally Desirable** Past contains no lead compounds traditionally found in this type of product.



WARNING: USING OTHER TYPES OF ANTI-SEIZE NOT RECOMMENDED BY APE CAN LEAD TO EQUIPMENT FAILURE OR PERSONAL INJURY. WARRANTY WILL BE VOIDED AND FEES MAY APPLY.

REFERENCE / NOTES



All information given in this Manual is current and valid per the information available at the time of publication. (Please check the updated revision date at the bottom of each page.)

American Piledriving Equipment, Inc. (APE) reserves the right to implement changes without prior notice.

Please visit www.americanpiledriving.com for the most recent version of this publication.

AMERICAN PILEDRIVING EQUIPMENT, INC.

7032 S. 196th Street
Kent, Washington 98032
Office: 253-872-0141
Toll Free: 800-248-8498
Fax: 253-872-8710



800-248-8498

WWW.AMERICANPILEDRIVING.COM

MODEL D46-52 • D50-52

Copyright © 2022 American Piledriving Equipment Inc. All Rights Reserved